



## **Manual Tilt Wheelchair Model 587**

# **Owner, Operator, and Maintenance Manual**



BRODA Seating  
560 Bingemans Centre Drive Kitchener, ON Canada N2B 3X9  
Phone: (800)-668-0637 Fax: (519) 746-8616  
[www.brodaseating.com](http://www.brodaseating.com) Email: [sales@brodaseating.com](mailto:sales@brodaseating.com)

## TABLE OF CONTENTS

WARNING .....	3
ComfortTilt SPECIFICATIONS.....	3
GENERAL INSTRUCTIONS .....	3
SECTION 1 - SAFETY REQUIREMENTS & DETAILED WARNINGS.....	5
1.1 Before First Use WARNING .....	6
1.2 Application WARNING.....	6
1.3 Legal Restrictions WARNING.....	6
1.4 Position of Wheelchair “Danger of Falling” WARNING .....	7
1.5 Position of Seat Tilt “Danger of Tipping” WARNING.....	7
1.6 Wheelchair Placement “Danger of Tipping” WARNING.....	7
1.7 Locking Wheels “Danger of Falling” WARNING .....	7
1.8 Re-Positioning of Patient “Danger of Pinching” WARNING .....	8
1.9 Accidental Motion “Danger of Falling or Collision” WARNING.....	8
1.10 Improper Restraint Use “Risk of Serious Injury” WARNING .....	8
1.11 Improper Use WARNING .....	9
1.12 Cleaning WARNING .....	9
1.13 Preventative Maintenance WARNING.....	9
1.14 Patient Specific Instructions WARNING .....	10
SECTION 2 - DEFINITIONS AND TECHNICAL INFORMATION.....	13
2.1 Definitions.....	13
2.2 Technical Information .....	13
2.3 Shipping and Storage Specifications .....	14
2.4 Labels.....	14
SECTION 3 - CAREGIVER MANAGEMENT .....	15
SECTION 4 - WHEELCHAIR OPERATION .....	16
4.1 Armrests .....	16
4.2 Wheel Locks.....	17
4.3 Anti-Tippers.....	17
4.4 Seat Tilt .....	19
4.5 Accessories.....	20
4.6 Adjustable Headrest .....	20
4.7 Seat Depth Adjustment.....	20
4.8 Seat Height Adjustment.....	21
4.9 Leg Rests .....	22
SECTION 5 - WHEELCHAIR REPAIR AND MAINTENANCE .....	25
5.1 Broda Chair Inspection/Maintenance Schedule* .....	25
5.2 Functional Testing .....	26
5.3 Cables and Cable Handles.....	27
5.4 Rear Wheels.....	28
5.5 Gas Cylinders .....	29
APPENDIX 1 - BRODA WARRANTY .....	32

## WARNING

DO NOT OPERATE THE BRODA COMFORTTILT WITHOUT FIRST READING AND UNDERSTANDING THIS MANUAL. IF FOR ANY REASON THE WARNINGS OR INSTRUCTIONS ARE UNCLEAR, CONTACT BRODA SEATING AT 1 (800) 668-0637 FOR CLARIFICATION. DO NOT ATTEMPT TO USE WHEELCHAIR WITHOUT FULLY UNDERSTANDING THE WHEELCHAIR AND ITS OPERATION AS IT MAY RESULT IN INJURY OR DAMAGE.

## ComfortTilt SPECIFICATIONS

Item	Standard	Available Options
Weight Capacity	250 lbs	250 lbs.
Seat Depth	18"	16", 17", 18" 19", 20" adjustable
Seat Height	18"	14", 15", 16", 17", 18", 19" adjustable
Seat Width	18"	16", 18", 20", 22"
Overall Width	27.5"	25.5", 27.5", 29.5"
Degrees of Tilt	Up to 45° Tilt	Up to 45° Tilt
Back Angle	10 degrees	Adjustable to 5, 10, 15, 20 degrees
Arm Type	Height Adjustable, Removable	Height Adjustable, Removable
Front Wheels	6" Swivel	5", 6", 8" Swivel
Rear Wheels	22"	20", 22", 24"
Frame Color	Black Hammertone	Black Hammertone
Weight (varies with options)	Approx. 40 lbs (does not include front rigging, headrest, wheels, seat pan, seat or back cushions)	
Leg rests	Swing-Away / Adjustable Length with Angle Adjustable Foot Plates	

## GENERAL INSTRUCTIONS

The instructions contained herein provide guidance on the safe and correct operation of the BRODA ComfortTilt Manual Wheelchair. Safety measures as described in Section 1 must be observed when operating the wheelchair's functions or moving the wheelchair.

Every person that is involved with the operation and maintenance of the BRODA wheelchair, including the patient's family members, must read this instruction manual prior to moving or operating the functions of this wheelchair. A copy of this instruction manual must always be available to these people. No person, including the patient's family members, who is unfamiliar with or is unwilling or unable to adhere to the safety and operating instructions contained herein, should be permitted to operate or move the wheelchair.

The BRODA ComfortTilt's intended use is to provide mobility to persons that may be limited to a sitting position. It is highly recommended that someone such as a nurse, nursing home staff or family member operate this device to transport patient(s) on even surfaces for safety and effectiveness. The BRODA ComfortTilt will be primarily used, but not limited to use, by residents in Nursing Homes and institutional settings. It is the responsibility of the user, with the help of his/her qualified healthcare professional, to determine the type of chair required for the individual.

The safety and operating instructions that are included in this manual are very important to the safe and effective operation of the BRODA ComfortTilt. Safety requirements that are detailed in Section 1 must be followed at all times.

BRODA accepts no liability whatsoever for damage or disruptions caused by operating errors, failure to provide proper maintenance, or the disregard of the instructions contained in this manual. This also includes the patient's specific instructions.

BRODA reserves the right to make changes to the specifications of the dimensions, functions, and components of its products. Any diagrams or drawings provided are not necessarily exactly the same as the delivered products.

Each BRODA wheelchair is provided with a unique, identifying serial number. This serial number should be maintained on the wheelchair and with your equipment records for future reference to obtain replacement parts or additional copies of the operating instructions.

## **SECTION 1 - SAFETY REQUIREMENTS & DETAILED WARNINGS**

This section must be read by all operators of the BRODA wheelchair before they attempt to use the product. It is the caregiver's primary responsibility to ensure that only people who are familiar with the information contained in this manual are authorized to operate or move the wheelchair.

Before operating the chair with the patient in the chair, make sure the patient is properly positioned to maintain patient and caregiver safety, as well as maintaining the maximum stability of the chair.

Caregivers must be prepared to support the weight of the patient in the chair when tilting and returning the occupant of the wheelchair to the full upright position. Always make sure to use proper body mechanics while operating the chair, to avoid injury.

All service and adjustments to the chair should be performed only while the chair is unoccupied.

Immediately after service and adjustments, and before use, always ensure all components of the chair are securely tightened and in proper working order, otherwise damage or injury may occur.

Always determine your safety limits by practicing maneuvers you would perform using the chair, such as bending, leaning, transferring, and reaching, in the presence of a qualified healthcare professional.

Always ensure anti-tippers are attached and adjusted to prevent the wheelchair from tipping over.

Do not lean forward out of the wheelchair any further than the length of the armrests. Make sure the casters are pointing forward when leaning forward. Otherwise, the chair may tip over.

Do not lift the chair by any removable parts. This action may result in damage to the chair, or injury to the user.

Do not attempt to pick up objects on the floor by leaning forward and reaching down between your knees. This may cause the chair to tip forward.

Do not lean backward over the chair back when in a tilt position. Doing so may cause the chair to tip over.

Do not attempt to propel the wheelchair from a tilted position. Otherwise the chair may tip over.

Do not attempt transfers from a tilted position. Otherwise the chair may tip over.

Do not attempt to maneuver or park on slopes greater than 9°. Otherwise the chair may tip over.

Always engage wheel locks before attempting to transfer in or out of the wheelchair. The wheel locks are not brakes and should not be used to stop a moving chair, as the chair may tip over.

Do not attempt to climb or descend slopes greater than 9°, go over curbs or obstacles, operate on roads or streets, or use an escalator to move a wheelchair between floors. Doing so may cause the chair to tip over and cause bodily harm to you, the occupant of the chair, or cause damage to the chair itself.

Do not use the footplates for transfers. Do not stand on the footplates. When performing transfers, or getting in or out of the chair, ensure the footplates are in an upright position or removed.

### **1.1 Before First Use WARNING**

BRODA wheelchairs are considered ready to use after purchaser inspection, functional testing, and when all training requirements have been met by qualified caregivers after receipt of wheelchair. Some assembly might be required. If the wheelchair does not appear to be in "ready to use" condition upon receipt, immediately contact your supplier and do not put the wheelchair into service until after your concerns have been resolved.

This manual must be read thoroughly by the caregiver(s) directly responsible for the patient's nursing care before the wheelchair is put into service. This manual must also be read thoroughly by new caregivers, prior to the first time a new caregiver operates or moves the wheelchair, once the wheelchair has been put into service. The patient's family members, who share some of the responsibility for the patient's care, are considered a caregiver only after they have read this manual, received instruction on the wheelchair's safe use by a professional caregiver, and a caregiver directly responsible for the patient's care has given their approval.

The wheelchair must be visually inspected for damage, missing parts, and loose fittings (fasteners) prior to first use or testing the wheelchair's functions. Functional testing must be successfully completed after visual inspection and before first use. These obligations apply both to the first use of the wheelchair and to all subsequent uses.

An in-service on the operation and safety issues, as described in this manual, must be given to the patient's caregivers prior to its first use.

### **1.2 Application WARNING**

The BRODA ComfortTilt Manual Wheelchair will be primarily used, but not limited for use by residents in a Nursing Home or institutional setting. The suitability and application of a BRODA wheelchair is to be determined by a professional caregiver who is familiar with the seating needs of the patient using the wheelchair. Any other use of the wheelchair is excluded from possible liability claims, and may void the warranty.

The ComfortTilt is not to be used in the shower. Use in the shower will void the warranty.

BRODA does not recommend that the user of this chair be transported in vehicles while in the wheelchair and that appropriate seating in vehicles is provided for the user as made available by the auto industry. BRODA does not recommend or endorse any wheelchair transportation system.

The wheelchairs are not explosion resistant and may only be used where there are no inflammable gases or liquids present such as anesthetics or petroleum based cleaners

The Broda ComfortTilt Wheelchair is designed for use with suitable aftermarket accessories, such as seat cushions and backs. Replacement parts for original chairs should be specific Broda replacement parts.

### **1.3 Legal Restrictions WARNING**

BRODA wheelchairs may only be used as described in this manual and with proper regard for recognized healthcare and work place safety and accident prevention practices.

The wheelchair may only be moved or operated by caregivers or family members who can guarantee its correct operation because they have read and fully understand this manual and the safety issues discussed herein

#### **1.4 Position of Wheelchair “Danger of Falling” WARNING**

After a patient is transferred into a wheelchair, assess the amount of tilt required. We recommend that the wheelchair’s seat be tilted sufficiently to prevent the patient from sliding or falling forward off the wheelchair. The amount of seat tilt used should be determined by the patient’s caregiver who is responsible for seating.

We recommend that the patient’s feet be correctly positioned on the footrests to prevent the patient from sliding or falling forward off the wheelchair. The amount of elevation used should be determined by the patient’s caregiver who is responsible for seating.

#### **1.5 Position of Seat Tilt “Danger of Tipping” WARNING**

In an attempt to prevent agitated patients from falling out of the wheelchair or tipping the wheelchair forward, the caregiver may decide to tilt the wheelchair. The amount of seat tilt used should be determined by the patient’s caregiver who is responsible for seating. Always ensure the patient is properly positioned in the chair before tilting.

Before operating the seat tilt, carefully read through section 1.8 Repositioning of Patient “Danger of Pinching.”

#### **1.6 Wheelchair Placement “Danger of Tipping” WARNING**

We recommend that when a patient has been moved to their destination, the wheelchair is placed so the patient cannot reach handrails or other objects, fixed or moveable. This is to prevent the patient from pulling the wheelchair over or pulling themselves off the seating surface, and to prevent the patients from pulling moveable objects onto the wheelchair and on themselves.

We recommend that the wheelchair be used in a supervised area to prevent untrained patients, caregivers, or third parties from unauthorized operation, movement, or unsafe actions such as sitting, standing or leaning on the reclined back, footrest, or the armrests. Individuals should not stand on the seat. These actions, if not prevented, could put the wheelchair at risk of tipping or may damage the wheelchair.

The seat depth, back height, size and position of the wheels, use of the anti-tippers, as well as custom dimensions or changes relate directly to the stability of the chair. Any adjustments to the above items must only be recommended or performed by an individual qualified to do so.

We recommend that a wheelchair only be used on a level surface to minimize the risk of tipping over.

All BRODA ComfortTilt’s are equipped with anti-tippers which are removable and adjustable. However, they should remain attached to the chair and pointed downward at all times. The anti-tippers can be pointed upward if necessary for traveling over a curb or such, however they must be returned to the standard downward position for standard traveling and when the chair is in a stationary position.

#### **1.7 Locking Wheels “Danger of Falling” WARNING**

The wheel locks must always be applied when:

- The wheelchair is not in use.
- A patient is being transferred (moved) into or out of the wheelchair.

- The patient in the wheelchair is not being moved by a caregiver.

It is important to note that if the wheel locks are applied while the patient is in the chair, that the caregiver does not leave the patient unattended, especially those patients who have the capability or tendency to propel the chair on their own, and/or those who may be agitated. This could cause harm to the patient if they attempt to propel the chair while the wheel locks are applied.

Failure to follow these instructions will unnecessarily increase the risk of serious falls by patients, caregivers, or third parties caused by the wheelchair unintentionally moving.

### **1.8 Re-Positioning of Patient “Danger of Pinching” WARNING**

BRODA wheelchairs offer the benefits of seat tilt, a footrest, and adjustable, removable arms. During the movement of any of these functions, the following safety measures must be observed:

- The patient’s arms must be securely positioned inside the wheelchair frame with their hands on their body.
- The patient’s feet must be correctly positioned on the footrests.
- All of the wheelchair’s wheel locks must be applied.
- Only one caregiver at a time attempts to operate the wheelchair’s functions.
- Only one wheelchair function is operated at a time.
- The patient’s and caregiver’s body are clear of all pinch points before operating any of the chair functions

Failure to follow these safety measures can put the patient's or caregiver's limbs at risk of injury. Patients who may be unaware of their body position or unable to maintain a safe body position have the highest risk of injury from pinching and caregivers should be more cautious with these patients. A second caregiver may be required to ensure the safety of these patients during these operations.

### **1.9 Accidental Motion “Danger of Falling or Collision” WARNING**

We recommend BRODA wheelchairs for indoor use within a long-term care institution and where there is insufficient slope to cause the wheelchairs to move unaided. Wheelchairs used where the surface is uneven or sloped are at risk of unintended movement and could become a serious danger to the patient, caregiver(s), or a third party. We recommend that BRODA wheelchairs are located away from stairwells, elevators, and exterior doorways. Placing the patient near handrails, tables or stationary objects while the wheel locks are in place should be done with caution and should be supervised. Failure to do so may lead to unnecessary injury due to the patient grabbing hold of the object and either pulling the object on top of them, or causing the chair to tip over.

### **1.10 Improper Restraint Use “Risk of Serious Injury” WARNING**

We recommend that alternatives to physical restraints be used with patients while seated in the wheelchair except under the specific instructions of the patient’s primary caregiver and with permission of the patient’s family or guardian. Physical restraints have been identified as a common cause of serious injury to patients while they are seated. We recommend that the primary caregiver responsible for seating first considers the re-positioning options available in the wheelchair to reduce the risks of sliding, falling, or self injury.



If a physical restraint is determined to be appropriate to prevent sliding or falling out of the wheelchair, BRODA supplies both seat belts and thigh belts. In all cases, it is the patient's primary caregiver who must take responsibility for the safety of the patient if restraints are used.

### **1.11 Improper Use WARNING**

The improper use of the wheelchair can be dangerous to the patient, caregiver, or a third party through:

- Unauthorized operation of the wheelchair's functions.
- Unauthorized movement of the wheelchair.
- Inappropriate use of the wheelchair by a patient who has not been assessed by the caregiver responsible for their seating.
- Attempted simultaneous operation of multiple wheelchair functions by one or more caregivers.
- Attempting to move the wheelchair with the wheel lock(s) applied.
- Applying wheel lock(s) while wheelchair is in motion
- Leaving the patient unattended in the wheelchair near other objects.
- Leaving a potentially agitated patient in an unsupervised area.
- Leaving a patient in a wheelchair on a sloping surface.
- Leaving a wheelchair unattended on a sloping surface.
- Leaving wheelchair unattended without setting wheel locks.
- Transferring a patient in or out of the wheelchair without setting wheel locks.
- Using the BRODA wheelchair at temperatures below 0° Celsius (32° Fahrenheit)

### **1.12 Cleaning WARNING**

The wheelchair should be wiped clean with soap and water. A dilute household strength ammonia or chlorine based cleaner may be used if necessary. Metal parts should be wiped dry after cleaning.

### **1.13 Preventative Maintenance WARNING**

The maintenance on a BRODA wheelchair will vary with the amount of use and the condition of the patient using the wheelchair. We recommend regular visual inspection for signs of wear, damage, loose or missing fittings, and other safety concerns. Also, periodic testing of the wheelchair's functions is appropriate. If a breakage, defect, or operational problem is detected, the wheelchair must be repaired, inspected and tested for function before it is returned to service. For regular use, the wheelchair should be inspected and tested on a bimonthly basis. The wheelchair should be inspected and tested as often as each use if the wheelchair is used:

- By aggressive or agitated patients.
- By patients who have involuntary movement.
- On irregular or sloped surfaces.
- By any unauthorized person.

Do not use any lubricants that contain solvents. Solvents will damage many of the moving components in the wheelchair. If necessary a white, food grade grease (lubricant) may be used on the sliding components in the wheelchair. Do not use spray lubricants as they contain solvents.

## **Inspection**

We recommend regular visual inspection of signs of wear, damage, loose or missing fittings, and other safety concerns. If a breakage, defect, or operational problem is detected, the chair must be repaired inspected and tested for function before it is returned to service.

We recommend that the wheelchair should be inspected as often as each use, if there is any reason to be concerned about the possibility of increased wear or loose or missing fittings. At a minimum, in regular use, the chair should be inspected on a bimonthly basis. The visual inspection procedure should include at least the observation of the following fasteners:

- The bolts and nuts, which attach the rear wheels to the wheelchair base.
- The bolts and nuts, which attach the front casters to the wheelchair base.
- The bolts and nuts, which attach the cylinder that positions the seat tilt
- The bolts and nuts, which attach the wheelchair back to the wheelchair seat.
- The bolts and nuts, which attach the wheelchair seat to the wheelchair base.
- The bolts and nuts, which attach the wheel-locks to the wheelchair base.

In addition, the visual inspection procedure should include the observation of the following parts:

- The cylinder that positions seat tilt
- The handles and cables
- The wheels and wheel locks

We also recommend the visual inspection procedure include the observation of any installed accessories.

## **Functional Testing**

**We recommend that the wheelchair operation be tested when unoccupied.** The testing may be as often as each use if there is any reason to be concerned about the possibility of above normal wear or damage to the chair's components.

If the caregiver performing the functional testing believes that any function is not operating correctly, the chair should be taken out of service until a satisfactory functional test can be completed.

**The caregiver performing the testing should be aware that the seat tilt operations will be more difficult when the wheelchair is unoccupied.**

When performing repairs or maintenance, do not use any lubricants that contain solvents. Solvents will damage many of the moving components in the chair. If necessary, a white, food grade grease lubricant may be used on the sliding components on the wheelchair. Do not use spray lubricants on any part of the chair.

### **1.14 Patient Specific Instructions WARNING**

The professional caregiver responsible for the patient's seating shall add such additional instructions as are necessary for the safety and comfort of the patient using the wheelchair based on their professional experience and knowledge of the patient's specific conditions and requirements. These instructions form a part of the Safety Requirements for using the wheelchair with that patient and must be made available to all caregivers.

## **Safety and Handling of Wheelchairs**

This manual describes the most common procedures and techniques involved in the safe handling and maintenance of BRODA chairs. It is important to understand, both conceptually and physically, the handling of the chair in order to prevent any injury to body, or misuse of the chair. The information provided here is to be regarded as a general guide and is based on techniques that have proven to be beneficial and successful by many users.

### **Stability and Balance**

Any activities that require movement in the wheelchair have an effect on the center of gravity of the chair. Therefore, it is very important not to lean forward out of the chair any further than the length of the armrests. Also, do not attempt to reach for objects on the floor by moving forward in your seat, or leaning over between the knees to pick them up.

If you do need to lean forward, ensure that the front casters are pointing forward to maintain the stability of the chair. You can do this by pushing forward and then reversing it in a straight line.

Leaning over the top of the back will change your center of gravity and may cause the chair to tip over. It is advisable to position the chair as close as possible to the desired object, and then point the front casters forward. Reach back only as far as your arm will extend without changing your sitting position.

When attempting a transfer in or out of the wheelchair, reduce the distance of the gap between the chair and the destination of the transfer. Ensure the casters are turned parallel to the object you are transferring onto, and that the wheel locks are engaged.

It is recommended that you practice bending, reaching and transferring activities with the help of a qualified healthcare professional before attempting such activities on your own. This will familiarize yourself and your caregiver with the particular safety limits of the chair.

It is important that if assistance is required with the use of the chair, that the caregiver remember to bend their knees, and keep their back straight whenever tipping the chair, or pushing the chair over curbs or other obstacles.

Lifting the chair by any removable or detachable parts may result in injury to the user, and will cause damage to the chair. Check for any signs of loose fittings periodically to ensure parts are secure. If parts are not secure, contact a qualified technician to assess, and repair, the chair before further use. Using the detachable parts to move the chair or as lift supports is inadvisable, as they may be inadvertently released causing possible injury or damage to the chair.

### **Tipping the Chair**

**Never tip the wheelchair without assistance.** When tipping the chair, the assistant should grasp the back of the chair on a non-removable part, informing the occupant of the chair as to what is about to happen and to lean back. It is important that the patient's feet and hands are clear of all pinch points and wheels.

For curbs, short stairs and other small obstacles, place your foot on the crossbar of the frame base and begin to tilt the wheelchair toward you. Push down in a continuous motion until a balance point is reached and until the front casters clear the obstacle. When lowering the chair, do not let the wheelchair drop the last few inches as this could cause an injury, or damage to the chair. Roll the wheelchair forward and slowly lower the front of the chair in a smooth, continuous motion. Push the wheelchair forward until the rear wheels roll up and over the obstacle. The assistant may be required to slightly lift the chair to help get the rear wheels over the obstruction.

If the anti tippers are repositioned upward during this operation, be sure to return them to their proper downward setting immediately after this operation.

### **Stairways**

BRODA does not recommend that the occupant be seated in the chair when moving the chair between floors when no elevator is available. If there is no other option, two assistants are required. With one assistant behind the chair, tilt the chair back to the balance point and back the chair up against the first step.

A second assistant, with a firm grasp on a non-detachable part of the frame, should lift the chair up and over the stair, steadying the chair as the first assistant places one foot on the next step and repeats the process.

Never use an escalator to move a wheelchair between floors.

## **SECTION 2 - DEFINITIONS AND TECHNICAL INFORMATION**

### **2.1 Definitions**

“BRODA” means BRODA Enterprises Inc. doing business as BRODA Seating. “Wheelchair” refers to BRODA Model ComfortTilt Manual Wheelchair.

“Long-Term Care Institution” refers to a Nursing Home, Hospital, or other Health Care facility that provides health and personal care to its residents on a long-term basis.

“Patient” refers to an individual using the wheelchair who may be limited to a sitting position.

“Professional Caregiver” refers to the Doctors, Nurses, Therapists, Nurses Aids, Health Care Aids, and other Specialists who provide health and personal care to its residents.

“Caregiver” refers to any person who is appropriately trained to provide care or services to the patient or the wheelchair used by the patient and may include the patient’s family members or guardian.

“Seat Tilt” refers to changing the angle of the wheelchair’s seat with respect to the wheelchair frame (or ground), without changing the angle between the back and the seat.

“Transfer(s)” refers to the movement of a resident into or out of a wheelchair with the assistance of their caregiver(s).

“Mechanical Transfer(s)” refers to the movement of a patient into or out of a wheelchair with the assistance of their caregiver(s) using a patient lift or other assistive device that bears the weight of the patient.

“Safety Requirements” are the important information contained in Section 1 which must be followed to ensure the safe operation of the wheelchair for the patient, caregivers, and third parties.

### **2.2 Technical Information**

#### Wheelchair Frame

The frame is constructed of solid and tubular steel. The base, seat, back, arms and footrest are powder coated for durability and corrosion resistance. The recommended maximum patient weight is 250 lbs (114 kg) for wheelchair widths up to and including 20”. Design loads were calculated using the maximum recommended occupant weight with the appropriate safety factors and testing was performed with a 100 kg ISO test dummy.

Adjustments to the seat tilt function are supported by a mechanical locking device designed to permit controlled movement during the operation of these functions. No motors or other powered devices are used in the wheelchair.

#### Casters and Wheels

The front wheels are swivel with non-marking rubber tires. The rear mount mag wheels are used for patients to propel themselves. Minimal maintenance is required for both casters and mag wheels, except for in extreme conditions as steam cleaning, pressure washing or autoclaving.

### Side Panels

Removable side panels provide support and containment of the patient while sitting in the wheelchair.

### Disinfection

For normal cleaning we recommend the wheelchair be wiped clean with soap and water. When necessary, a household strength diluted ammonia or chlorine based cleaner may be used. Metal parts and cushions should be wiped dry after cleaning.

## **2.3 Shipping and Storage Specifications**

BRODA wheelchairs should be shipped and stored in an upright condition and not stacked higher than 2 boxes. No other materials should be shipped or stored on top of a BRODA box. BRODA boxes should not be placed on pallets.

BRODA wheelchairs should be shipped and stored at temperatures between minus 20 degrees Celsius and plus 40 degrees Celsius. BRODA wheelchairs should not be used until they are between 0 degrees Celsius and 30 degrees Celsius. BRODA wheelchairs should be kept in a clean, dry environment.

On receipt, we recommend that the shipping carton be immediately examined for damage. Any damage should be noted on the delivery receipt and a request for inspection by the transportation company should be made. The shipping carton should be opened immediately and the wheelchair examined for concealed shipping damage. If the wheelchair appears to be damaged, contact the customer service department at BRODA Seating.

## **2.4 Labels**

### Weight Capacity Label

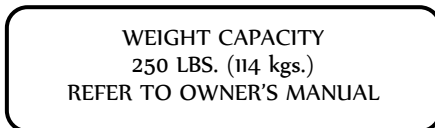

### Warning Label

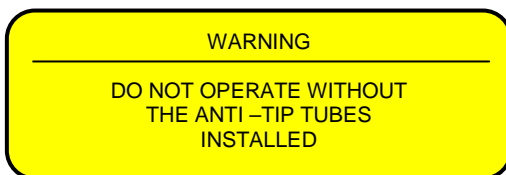

### Manufacturing Label



### Serial Number Label (Silver)



### Product Label



### **SECTION 3 - CAREGIVER MANAGEMENT**

BRODA's unique and innovative wheelchairs provide the optimum in re-positioning functions and mobility. However, BRODA's products were designed to be recommended by professional caregivers. The maximum benefit to the patient using this wheelchair will be achieved with the advice and assistance of their caregivers.

At the customer's request, the initial basic training of the patient's caregiver(s) will be provided by either the local BRODA representative who supplies the wheelchair or the HME Provider. The caregiver(s) must adhere to the Safety Requirements at all times to ensure the safety of the patient, caregivers, and third parties.

The customer will maintain a list of caregivers who have read this manual and are authorized by them to operate and move the wheelchair.

**WARNING** BRODA assumes no liability for damage, injury or accidents caused by careless, negligent, incorrect, or unauthorized operation or movement of its wheelchairs. It is the responsibility of the caregiver to ensure the patient is secure in the chair and that the proper degree of care is given based on the patients needs.

## SECTION 4 - WHEELCHAIR OPERATION

### 4.1 Armrests

The armrests are height adjustable and removable to accommodate various users and facilitate transfers and access to the user.



Arm Detent Pin

#### Armrests Removal and Installation

1. Push-in the Arm Detent Pins.
2. Once the Arm Detent Pins are disengaged, remove the Front and Rear Frame Insert by lifting the arm up.
3. To reinstall, insert the Back Frame Insert into the frame and then insert the Front Frame Insert into the frame. Push in front and rear Arm Detent Pins to secure arm in place.

#### Adjusting the Armrest Height

1. Squeeze the Arm Height Adjustment Pins together.
2. Raise or lower the arm top to the desired height. Release the pins and push down until the pins lock.

**Note:** Do not place fingers directly under the arm or at the top of the arm pins as this can cause pinching.



Arm Height Adjustment Pins

#### Replacing the Armrest Tops

1. Using a Phillips screwdriver loosen the 2 screws under the Arm Top.
2. Remove the Arm Top and place the new Arm Top on frame.
3. Screw the new Arm Top in place



## 4.2 Wheel Locks



Wheel Lock Handle  
(Push to Lock)

### Locking/Unlocking the Rear Wheels

1. To lock; push the Wheel Lock Handle towards the front of the wheelchair until the wheel is locked in place.
2. To unlock; pull the Wheel Lock Handle towards the back of the wheelchair until the wheel is unlocked.

### Adjusting the Wheel Lock

1. Ensure the wheel lock is unlocked.
2. Using a 5 mm Allen key wrench, loosen the 2 socket head bolts on top of the mounting clamp.
3. Once loose, slide the Locking Unit to the desired position and tighten.
4. Engage the lock and measure the distance the wheel lock is embedded into the tire. When engaged, the wheel lock must be embedded in the tire at least 1/8" to hold the wheelchair.
5. Repeat steps 1 through 4 if necessary until the 1/8" measurement is obtained.

## 4.3 Anti-Tippers

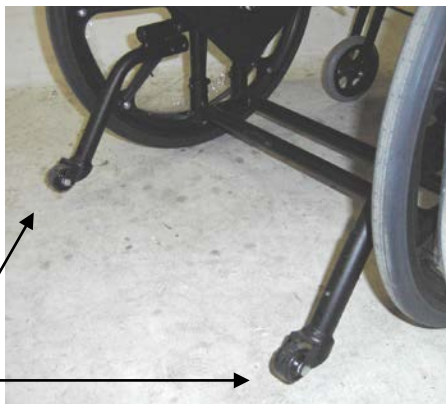

Anti-Tipper Wheels

All BRODA ComfortTilt's are equipped with anti-tippers which are removable and adjustable. However, they should remain attached to the chair and pointed downward at all times and adjusted to the longest possible setting. The anti-tippers can be pointed upward if necessary for traveling over a curb or such, however they must be returned to the standard downward position for standard traveling and when the chair is in a stationary position.

#### Adjusting the Anti-Tippers

1. Guidance for the anti-tipper height location holes is provided in the Table in Section 4.7. For making the height adjustments, the detent pin can be depressed and the anti-tipper height adjusted.



2. Guidance for the anti-tipper receiver mounting position is provided in the Table in Section 4.7. For making this adjustment, the receiver is removed using two ½" wrenches and undoing the bolts identified below (remove the anti-tippers, see item 3 in this section). Reinstalling the receiver to the alternate position in the table requires the component being stalled on the opposite side. So, if you are going from the lower position, the receiver is mounted on the opposite side and in the upper position. Reinstall the bolts.



3. To remove the anti-tippers, the detent pin on the receiver can be disengaged and the anti-tippers slid out. The detent pin may be on the top or bottom, depending on how the receivers are mounted.



#### 4.4 Seat Tilt

The ComfortTilt offers up to 45° of adjustable seat tilt. The gas spring used for the seat tilt feature allows the seat to be tilted to any position within its range. Use seat tilt to safely position the patient, redistribute pressure and increase comfort.



Tilt Handle

45° Seat Tilt

##### Adjusting Seat Tilt

1. With the patient in the wheelchair, squeeze the tilt handle which is located on the push bar.
2. Raise or lower the seat tilt until the desired angle is achieved. The amount of tilt used should be determined by the patient's caregiver who is responsible for seating.
3. Release tilt handle when the desired degree of tilt is achieved.

##### Adjusting Backrest Angle

1. Remove the selection bolt and loosen the pivot bolt on the adjustable plate on both sides of the chair.
4. Reposition the backrest angle to 5, 10, 15 or 20 degrees and install the positioning bolt.

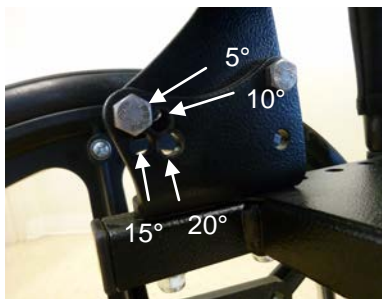

3. Tighten all bolts.

#### **4.5 Accessories**

Broda offers various accessories for the ComfortTilt Tilt Wheelchair, as well as accommodating various after-market accessories.

#### **4.6 Adjustable Headrest**

The headrest for the ComfortTilt is very versatile in its adjustability, allowing for a wide variety of positioning needs.

##### Attaching Headrest

1. Insert the vertical post into the mounting tube
2. Place the headrest at the desired height and tighten it in the mounting tube with the handle, until the headrest is secure.

#### **4.7 Seat Depth Adjustment**

The seat depth is adjustable with the solid seat pan to 16", 17", 18", 19", and 20".

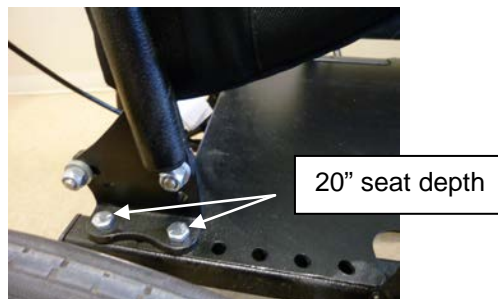

##### Adjusting Seat Depth

1. Remove the 2 bolts that attach the back cane brackets to the seat pan on both sides of the chair.
2. Reposition the back canes along the seat pan to the appropriate seat depth.
3. Re-insert the back cane bolts into the holes on both sides of the chair for the appropriate seat depth.
4. Tighten all bolts.

#### 4.8 Seat Height Adjustment

The seat height is adjustable with the base frame, wheels, and caster forks from 14" to 19".

##### Seat Height Adjustment:

- 1) Locate the caster fork adjustment positions on the front
- 2) Remove the screw and locknut that secure the caster to the fork.
- 3) Raise or lower the caster to the desired position (See the seat Height combination diagram to determine the desired position)
- 4) Insert the screw and locknut through the corresponding holes and tighten the bolts



Caster Fork

Note: To achieve 14" seat height you must install the seat in the lower hole on the base frame pivot tab.

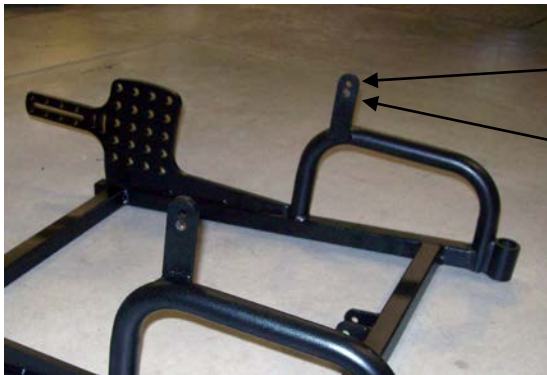

Upper Hole  
(Standard position)

Lower Hole  
(14" Seat height position)

Seat Height and Wheel Combinations Matrix:

587V3: SEAT HEIGHT & WHEEL COMBINATIONS								
SEAT HEIGHT	MAG WHEEL	CASTER WHEEL	CASTER FORK	MAG PLATE HOLE #	CASTER FORK HOLE #	ANTI-TIPPER MOUNT	ANTI-TIPPER HOLE #	SEAT TAB
14"	20	5	SMALL	1	1	TOP	3	2
15"	20	5	SMALL	2	2	TOP	2	1
	22	5	SMALL	1	2	TOP	2	1
15.5"	20	6	MEDIUM	2	1	TOP	2	1
	22	6	MEDIUM	1	1	TOP	2	1
	24	6	SMALL	1	2	TOP	1	1
	24	5	MEDIUM	1	2	TOP	1	1
	24	6	MEDIUM	1	1	TOP	1	1
16"	20	5	SMALL	3	3	TOP	1	1
	20	5	MEDIUM	3	3	TOP	1	1
	20	6	MEDIUM	3	2	TOP	1	1
	22	5	SMALL	2	3	TOP	1	1
	22	6	SMALL	2	2	TOP	1	1
	22	5	MEDIUM	2	3	TOP	1	1
	22	6	MEDIUM	2	2	TOP	1	1
	24	5	SMALL	1	3	TOP	1	1
16.5"	20	6	SMALL	3	3	TOP	1	1
	24	6	SMALL	2	3	BOTTOM	3	1
	24	5	MEDIUM	2	4	BOTTOM	3	1
	24	6	MEDIUM	2	3	BOTTOM	3	1
17"	20	5	MEDIUM	4	5	BOTTOM	3	1
	20	6	MEDIUM	4	4	BOTTOM	3	1
	22	5	MEDIUM	3	5	BOTTOM	3	1
	22	6	MEDIUM	3	4	BOTTOM	3	1
17.5"	20	8	SMALL	4	3	BOTTOM	3	1
	22	8	SMALL	3	3	BOTTOM	3	1
	24	8	SMALL	3	3	BOTTOM	2	1
	24	6	MEDIUM	3	5	BOTTOM	2	1
	24	8	MEDIUM	3	3	BOTTOM	2	1
18"	20	8	MEDIUM	5	4	BOTTOM	2	1
	22	8	MEDIUM	4	4	BOTTOM	2	1
19"	24	8	MEDIUM	4	5	BOTTOM	1	1

Hole numbering begins at the top of the plate, fork and anti-tipper. Hole number 1 is the uppermost hole.

Do not use the rear most vertical row/column of holes on the mag plate for 20" mag wheels

Form08CONFIG- 404 587V3 Rev. 1

#### 4.9 Leg Rests

Leg Rest installation and removal is accommodated via sliding the leg rest on to the receiving post at the corner of the seat. The leg rest is dropped on and slid back around as lowered, then once seated, pulled forward to latch. To swing the leg rest out of the way, depress the black tab and swing the leg rest out from the front of the chair. Re-engaging into position is done by swinging them back in place until they latch. Removal requires depressing the tab and swinging the leg rest part way out while lifting them out of the receiving post.

The leg rests are not designed to be stood upon, they are only a support for the leg and foot while seated in the chair.





The leg rests can be adjusted to length using an M4 hex key. The bolt is removed and the length can be extended or shortened via sliding the lower tube inside the upper tube. There are various hole options to select from for reinserting the bolt.



The foot plate can be moved fore and aft at the base of the leg rest, as well as adjusting the foot angle, using the same fastener set. The clamping mechanism has to be unbolted using a 10 mm wrench and an M4 hex key in order to reposition the plate placement fore and aft. The bolt and nut only need to be loosened to adjust the angle.



The lateral angle of the foot plate can be adjusted with an M4 hex key and a 10 mm wrench. Use the wrench to loosen the nut and adjust the hex bolt to reach the desired lateral angle. Tighten the nut with the 10 mm wrench when complete.





## SECTION 5 - WHEELCHAIR REPAIR AND MAINTENANCE

### 5.1 BRODA Chair Inspection/Maintenance Schedule\*

Part	Initial Inspection	Inspect/Adjust Weekly	Inspect/Adjust Monthly	Inspect/Adjust Periodically	Inspect/Adjust Regularly
<p><b><u>Gas Cylinders:</u></b>  <i>Check to ensure functions operated by cylinders are functioning properly:</i></p>	X		X		
<p><b><u>Cables and Handles:</u></b>  <i>Cables connected to cylinders  Cables completely release and handles return when released</i></p>	X	X			
<p><b><u>Upholstery:</u></b>  <i>Check for tears</i></p>	X			X	
<p><b><u>Casters/Wheels:</u></b>  <i>Inspect swivel casters for proper tension by spinning caster. Caster should come to a gradual stop.</i></p> <p><i>Loosen or tighten bolts if caster wobbles or comes to an abrupt stop.</i></p> <p><i>Check to ensure casters are clean and free of dirt</i></p> <p><i>Check to ensure all wheel locks are functioning</i></p> <p><i>Check for loosening attachment between caster stem and housing.</i></p> <p>CAUTION: Casters should be checked regularly for wear or cracks and should be replaced.</p>	X	X			
<p><b><u>Armrests:</u></b>  <i>Check to ensure height adjustment functions properly</i></p> <p><i>Ensure arms are secure, but easy to release where applicable</i></p>	X			X	
	X			X	

<b>Options/Accessories</b> <i>Inspect all Broda chair options and accessories to ensure proper working order</i>	X			X	
<b>Framework</b> <i>Check for cracks along weld seam of tube, especially around load carrying bends e.g. backrest/seat; cracks or tears around welds, especially around load carrying tabs e.g. cylinder mounting tabs</i>	X				X
<b>Fasteners</b> <i>Check for loose, missing or worn fasteners</i>					X

\*BRODA Chair Inspection/Maintenance Schedule is a guideline only  
 Detection of any of the above issues should be reported to BRODA. 1-800-668-0637.

### Inspection

Safety measures as described in Inspection/Maintenance schedule must be observed when inspecting or testing a chair. Only authorized caregivers or maintenance staff should attempt to inspect or test a chair.

BRODA recommends regular visual inspection for overall signs of wear, damage, loose or missing fittings, and other safety concerns. If a breakage, defect, or operational problem is detected, the chair must be repaired inspected and tested for function before it is returned to service.

BRODA recommends that the chair be inspected as often as each use if there is any reason to be concerned about the possibility of increased wear or loose or missing fittings.

The visual inspection should be performed by the facility, or if in a private residence, by the individual responsible for the chair.

### 5.2 Functional Testing

**BRODA recommends that the chair should be tested for operation of the chair's functions without a resident in the chair.** The testing may be as often as each use if there is any reason to be concerned about the possibility of increased wear or damage to the chair's components.

If the caregiver or maintenance department performing the functional testing believes that any function is not operating correctly, **the chair should be taken out of service until a satisfactory functional test can be completed.**

**The caregiver or maintenance department performing the testing should be aware that the seat tilt, back recline, and footrest (leg rest) elevation operations will be more difficult without a resident in the chair.**

When performing repairs or maintenance, do not use lubricants that contain solvents. Solvents will damage many of the moving components in the chair. If necessary, a white, food grade grease (lubricant) may be used on the sliding components in the chair. Do not use spray lubricants on any part of the chair.

**WARNING:**

After any adjustments, repair or service, before use, make sure all attaching hardware is tightened securely. Otherwise injury or damage may result.

**CAUTION:**

DO NOT over-tighten hardware as this could cause damage to the frame.

Note: Please include the model number and serial number of the wheelchair whenever you are ordering parts. These can be found on a sticker that is attached to the base on the bottom of the chair.

NOTE: Only a person with training on the BRODA chair should attempt to do any repairs or maintenance on the wheelchair. Certain repairs may require a BRODA representative to personally attend to the repair. If you are unsure as to what is required, call BRODA customer service at 1-800-668-0637.

**5.3 Cables and Cable Handles**

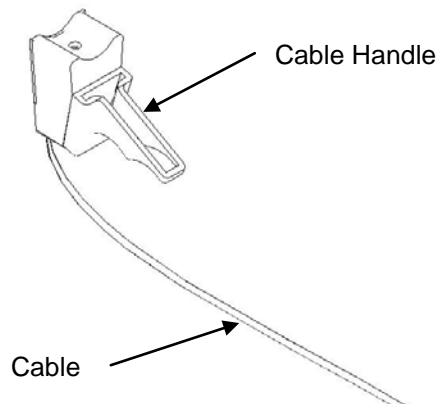

**Maintaining the Cables and Cable Handles**

The cables and cable handles do not require any maintenance. Both replacement pieces are shipped together fully assembled.

**Removing and Installing the Cables and Cable Handles**

The cable is used in conjunction with a cable handle and an actuator to control the function of the gas cylinder. The cable is held in place on the handle end by a cable housing retaining clip. On the actuator end the cable hooks into the lever that depresses the control pin on the cylinder and the cable housing clip into the actuator housing.

1. Loosen the nut on the bottom of the cylinder. Unclip the cable from the actuator lever on the cylinder.

2. Cut the cable ties that secure the cable to the frame of the wheelchair (carefully note the location of the cable ties and how the cable is routed around the frame of the wheelchair.)
3. Unscrew the tilt handle from the frame.
4. Remount the new handle assembly to the frame of the wheelchair using the screw removed in step 3.
5. Route the new cable around the frame of the wheelchair the same as the previous one and install new cable ties where necessary.
6. Attach the end of the cable into the actuator lever the same way removed in step 1.
7. Secure the cable clip to the end of the cable attached to the actuator and tighten the nut on the bottom of the cylinder.

#### 5.4 Rear Wheels

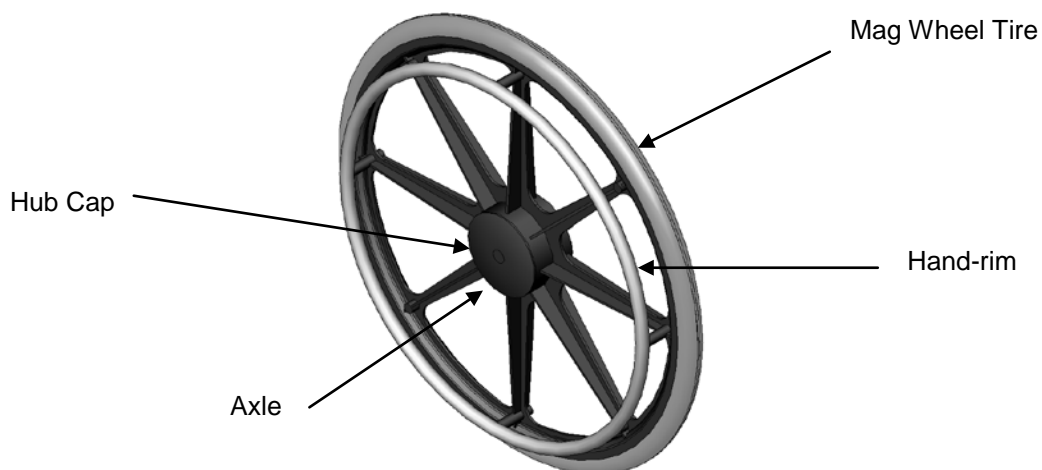

##### Removing and Installing the Rear Mag Wheels

1. Remove hubcap from wheel by turning counter clock-wise by hand
2. Using a 5/8" combination wrench, loosen hex screw and locknut at axle of wheel
3. To install, reverse steps 1-2.  
Ensure that the head of the bolt is towards the inside and the nut is on the outside

Note: The rear mag wheels can be mounted in 5 vertical positions on the mounting plate, depending on the seat height required and combination of mag wheel selected.

The rear mag wheel can also be mounted horizontally along the mounting plate.

Mag wheel  
mounting plate



### Replacing the Rear Wheel Hand Rim

1. Remove rear wheel(s) from wheelchair (see Removing/Installing the Rear Wheels)
2. Remove the mounting screws from the inside of the wheel using a Phillips screwdriver
3. Remove existing hand rim
4. Install new hand rim by reversing above steps
5. Reinstall rear wheel (see Removing/Installing the Rear Wheels section for instructions)

### **5.5 Gas Cylinders**

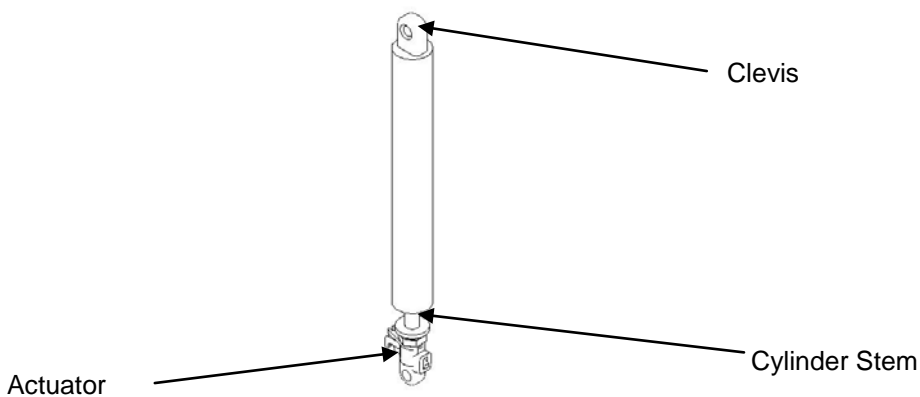

The use of gas charged springs on BRODA products allow the caregiver to easily make adjustments to the tilt and recline with a minimum amount of effort. The gas cylinders contain pressurized Nitrogen gas, it is not flammable nor is it toxic. The cylinder(s) provide 800 Newton's (180 lbs.) of force. The cylinder(s) provide assistance and reduce the amount of effort required by the care giver to tilt the chair.

<b>Part No.</b>	<b>Description</b>
CYL-800N-587	Cylinder PAB6 800N

### How do they work?

On the end of the stem of the cylinder is a small pin. When the operator depresses the handle this pulls on the cable which in turn pulls on a small lever inside the actuator mechanism into which the stem of the cylinder is mounted. This depresses the pin which opens a valve located inside the barrel of the cylinder, allowing for changes in position. When the operator releases the handle, the valve closes and locks the cylinder in the desired position.

The function of the actuator is to push against the pin and open the valve that controls the cylinder. If the actuator is not properly adjusted when mounted on the cylinder, problems will occur.

### Maintenance

The gas cylinders generally do not require any maintenance. Adjustments may be needed due to cable stretch.

**When adjusting the cylinder it is important that you do not damage the stem on the cylinder. Small scratches left by applying the jaws of pliers or Vice Grips directly to the shaft while making adjustments will destroy the seal and allow the gas inside the cylinder to escape. Use a piece of cloth or rubber to protect the cylinder shaft from the tools you are using to make the adjustments!**

### Troubleshooting the Cylinders

Often, when experiencing problems with cylinders on BRODA wheelchairs, the cylinder is not damaged, it usually only requires an adjustment. There are two common adjustments.

1. The pin that the cable handle pulls on at the end of the cylinder is not connected correctly.
2. The handle or cable assembly is broken or disconnected.

Other solutions to common problems are listed below.

- **The wheelchair is not tilting when cylinder handle is pulled.**  
The pin in the end of the cylinder is not being depressed when the handle is pulled. Action to take: See adjustment steps that follow
- **The wheelchair tilt seems to slowly slide out of position.**  
The pin in the end of the cylinder may be still partially depressed. Action to take: See adjustment steps that follow.

### Adjusting the Cylinders

**Note: Cylinder does not need to be removed from the wheelchair to make this adjustment.**

1. Loosen the lock nut located on the stem of the gas cylinder, next to the actuator, with a 17mm wrench.
2. From the above instructions, determine whether you want to wind the stem further into the actuator or further out of the actuator. You will need to wind the stem further into the

actuator if the chair is not tilting (wind it clockwise) and wind it further out of the actuator if the chair is slowly sliding out of position. (wind it counter clockwise)

3. Check the function of the cylinder and repeat steps 3 & 4 until the cylinder functions properly.
4. Tighten the lock nut loosened in step 1.

#### Removing and Installing the Cylinders

1. Remove the 5/16" mounting bolt from the end of the cylinder (requires 2 x 1/2" wrenches).
2. Loosen the lock nut located on the stem of the cylinder by the actuator.
3. Wind the stem of the cylinder out of the actuator.
4. Wind the stem of the new cylinder into the actuator.
5. Reinstall the 5/16" mounting bolt.
6. Adjust the cylinder as per the above adjustment instructions.

## **APPENDIX 1 - BRODA WARRANTY**

### **BRODA Seating**

(a Division of BRODA ENTERPRISES INC.)  
560 Bingham Centre Drive, Kitchener, ON Canada N2B 3X9  
Phone: (519) 746-8080 Toll Free 1-800-668-0637  
Fax: (519) 746-8616

### **GENERAL INFORMATION WARRANTY**

BRODA provides a Three Year Warranty on the wheelchair frame and cross braces, and a One Year Warranty on all other components subject to the following conditions:

The wheelchair frames and cross braces are guaranteed for Three Years against structural defects or failure. All other parts including but not limited to cushions, gas springs and attachments, casters, wheels, brakes and armrests are guaranteed for one year against defects in materials and workmanship based on normal institutional use. The guarantee does not cover malicious or deliberate damage or damage from misuse.

This warranty does not cover shipping damage (see below).

BRODA will provide new or refurbished parts for installation by the owner at no cost following confirmation by the local BRODA Representative or the BRODA Head Office Customer Service Representative. On request, defective parts must be returned to the factory within thirty days of receipt of the replacement parts by the owner. If the defective parts are not returned to BRODA on request, the owner will bear the cost of the replacement parts on invoice from BRODA.

Warranty does not include on-site labor for the installation of warranty parts or warranty repairs. The owner may return to BRODA products for warranty replacement or repair by shipping items prepaid and insured to the factory. Warranty completed at the factory includes both materials and labor. Parts to be repaired or replaced are at the discretion of BRODA. All returns to the factory require prior authorization from BRODA.

BRODA retains the right to make design and application changes without notice. All orders will be filled with BRODA's current models unless otherwise specified by the purchaser.

BRODA wheelchairs are designed for patient mobility, positioning, and comfort in specialty seating, however, the application of BRODA products shall remain the responsibility of the purchaser or user.

This warranty is not transferable.

### **RETURNS**

BRODA Seating will not accept any returns without a prior Returned Goods Authorization Number. Please contact our Head Office Customer Service Representative at 1-800-668-0637 for assistance. Returns must be insured when shipped.

### **DAMAGED FREIGHT NOTIFY THE CARRIER OF ANY DAMAGE IMMEDIATELY**

It is the responsibility of the person receiving the goods to examine cartons and goods before accepting receipt. Note all damages on the bill of lading and file a claim if necessary. Notify the carrier of any concealed damaged within a maximum of 48 hours.

BRODA insures all products for in transit damage, failure to notify the carrier of in transit damage voids both the insurance and the BRODA warranty. If you require assistance, please contact our Head Office at 1-800-668-0637

### **SALES TAX**

Most BRODA products are G.S.T. Zero Rated and Exempt from Canadian Provincial Sales Tax. Purchasers may be required to check with their Provincial or State Tax Office for purchaser tax payment.